

WIPERS

CUSTOMER		DATE	
MATERIAL		QUANTITY	
<i>Fill circle below profile requested</i>		REQUIRED DATE	

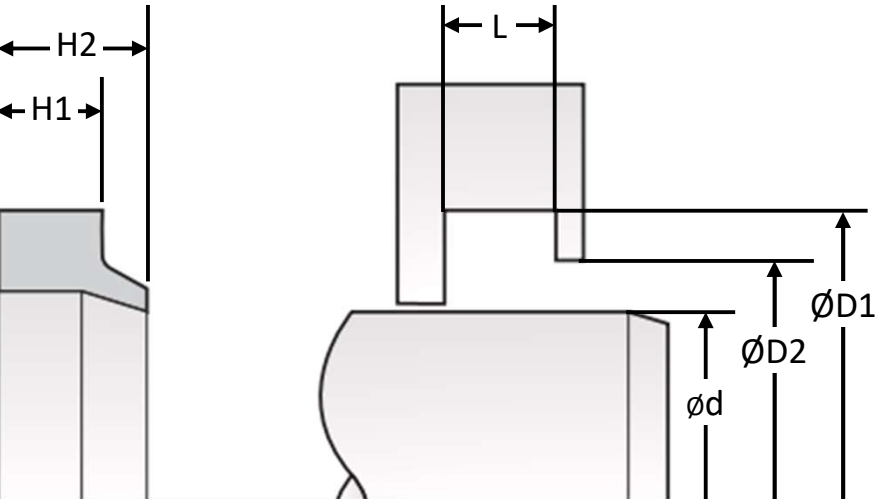

Rod Dia. (ϕd)	
Groove Dia. ($\phi D1$)	
Shoulder Dia. ($\phi D2$)	
Groove Width (L)	
Seal Height 1 (H1)	
Seal Height 2 (H2)	
SECONDARY COMPONENTS	
TO BE MACHINED	MATERIAL
LOADER	Y / N

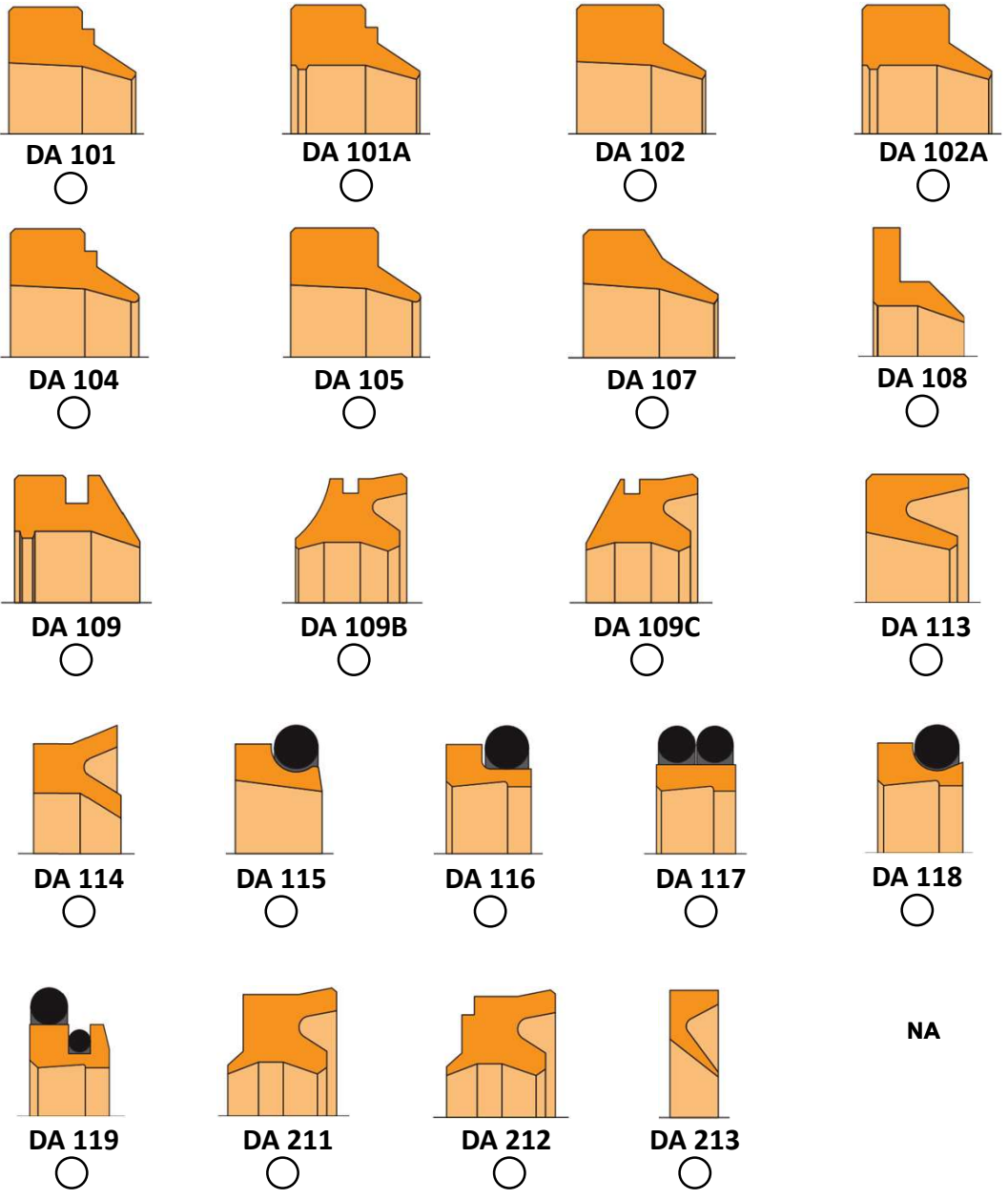

NOTES: