

ENGINEERING SERVICES

PSP Seals' four in-house, experienced engineers create innovative and effective solutions to the most perplexing sealing problems. Our material expertise includes various rubber compounds, Polyurethane, PTFE compounds and engineered plastics.

- Seal & Gasket Selection
- Material Specification
- Material Testing
- Application Engineering Support
- Problem Solving
- Custom Seal Design & Development
- Failure Analysis
- Value Analysis
- Finite Element Analysis
- Product Validation Testing
- Reverse Engineering
- Non-Contact Measurement (Keyence)
- Computer Aided Design Modeling
- On-Site Trouble Shooting & Support
- Packaging & Label Support
- First Article Inspection
- PPAP

Additionally, as a top authorized distributor for Parker Engineered Materials Group and others, their engineers are readily available to assist us and our customers to develop new materials and products for new applications.

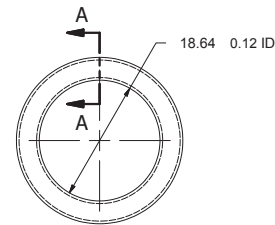
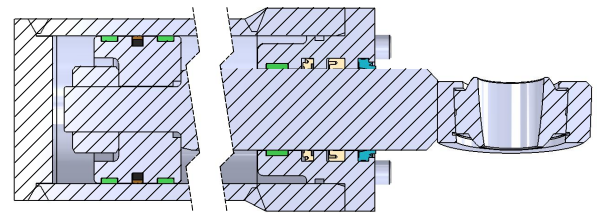

NOTES:

- 1.) ALL DIMENSIONS ARE IN MILLIMETERS
- 2.) MATERIAL: PUHP94 POLYURETHANE

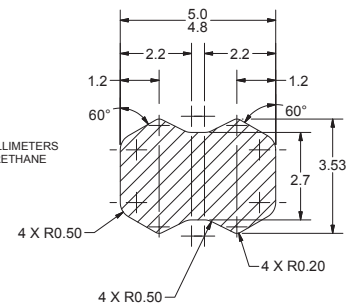

SECTION A-A

PSP Seals provides 100+ combined years of seal experience via our in-house engineering team. Founded in 2000 as an engineering driven, stocking distributor specializing in customized sealing solutions.

Engineered Solutions. Personal Support. Global Resources.

